

# You downloaded this paper through cbse.biz

## Design of Question Paper

### Mathematics - Class X

Time : Three hours

Max. Marks : 80

Weightage and distribution of marks over different dimensions of the question paper shall be as follows:

#### A. Weightage to content units

S.No.	Content Units	Marks
1.	Number systems	04
2.	Algebra	20
3.	Trigonometry	12
4.	Coordinate Geometry	08
5.	Geometry	16
6.	Mensuration	10
7.	Statistics & Probability	10
<b>Total</b>		<b>80</b>

#### B. Weightage to forms of questions

S.No.	Forms of Questions	Marks of each question	No. of Questions	Total marks
1.	Very Short answer questions (VSA)	01	10	10
2.	Short answer questions-I (SAI)	02	05	10
3.	Short answer questions-II (SAII)	03	10	30
4.	Long answer questions (LA)	06	05	30
<b>Total</b>			<b>30</b>	<b>80</b>

#### C. Scheme of Options

All questions are compulsory. There is no overall choice in the question paper. However, internal choice has been provided in one question of two marks each, three questions of three marks each and two questions of six marks each.

#### D. Weightage to difficulty level of Questions

S.No.	Estimated difficulty level of questions	Percentage of marks
1.	Easy	15
2.	Average	70
3.	Difficult	15

Based on the above design, separate Sample papers along with their blue print and marking scheme have been included in this document for Board's examination. The design of the question paper will remain the same whereas the blue print based on this design may change.

**Mathematics-X**  
**Blue Print I**

<b>Unit</b>	<b>Form of Questions</b>	VSA (1 Mark) each	SAI (2 Marks) each	SA II (3 Marks) each	LA (6 Marks) each	Total
Number systems		1(1)	—	3(1)	—	4(2)
Algebra		3(3)	2(1)	9(3)	6(1)	20(8)
Trigonometry		1(1)	2(1)	3(1)	6(1)	12(4)
Coordinate Geometry		—	2(1)	6(2)	—	8(3)
Geometry		2(2)	2(1)	6(2)	6(1)	16(6)
Mensuration		1(1)	—	3(1)	6(1)	10(3)
Statistic and Probability		2(2)	2(1)	—	6(1)	10(4)
<b>Total</b>		<b>10(10)</b>	<b>10(5)</b>	<b>30(10)</b>	<b>30(5)</b>	<b>80(30)</b>

**Sample Question Paper - I**  
**Mathematics - Class X**

**Time : Three hours**

**Max.Marks :80**

**General Instructions.**

1. All Questions are compulsory.
2. The question paper consists of thirty questions divided into 4 sections A, B, C and D. Section A comprises of ten questions of 01 mark each, section B comprises of five questions of 02 marks each, section C comprises of ten questions of 03 marks each and section D comprises of five questions of 06 marks each.
3. All questions in Section A are to be answered in one word, one sentence or as per the exact requirement of the question.
4. There is no overall choice. However, internal choice has been provided in one question of 02 marks each, three questions of 03 marks each and two questions of 06 marks each. You have to attempt only one of the alternatives in all such questions.
5. In question on construction, drawings should be neat and exactly as per the given measurements.
6. Use of calculators is not permitted. However you may ask for mathematical tables.

---

**Section A**

1. Write the condition to be satisfied by  $q$  so that a rational number  $\frac{p}{q}$  has a terminating decimal expansion.
2. The sum and product of the zeroes of a quadratic polynomial are  $-\frac{1}{2}$  and  $-3$  respectively. What is the quadratic polynomial?
3. For what value of  $k$  the quadratic equation  $x^2 - kx + 4 = 0$  has equal roots?
4. Given that  $\tan\theta = \frac{1}{\sqrt{5}}$ , what is the value of  $\frac{\operatorname{cosec}^2\theta - \sec^2\theta}{\operatorname{cosec}^2\theta + \sec^2\theta}$
5. Which term of the sequence 114, 109, 104 .... is the first negative term ?

6. A cylinder, a cone and a hemisphere are of equal base and have the same height. What is the ratio in their volumes?

7. In the given figure, DE is parallel to BC and  $AD = 1\text{cm}$ ,  $BD = 2\text{cm}$ . What is the ratio of the area of  $\triangle ABC$  to the area of  $\triangle ADE$ ?

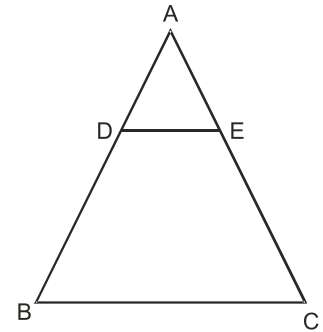

8. In the figure given below, PA and PB are tangents to the circle drawn from an external point P. CD is a third tangent touching the circle at Q. If  $PB = 10\text{cm}$ , and  $CQ = 2\text{cm}$ , what is the length of PC?

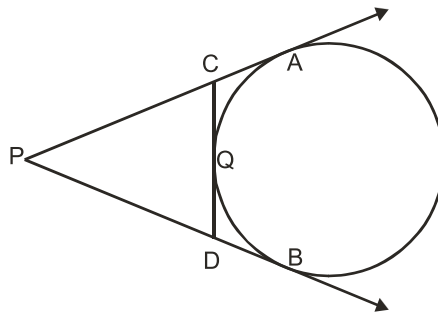

9. Cards each marked with one of the numbers 4,5,6....20 are placed in a box and mixed thoroughly. One card is drawn at random from the box. What is the probability of getting an even prime number ?

10. A student draws a cumulative frequency curve for the marks obtained by 40 students of a class, as shown below. Find the median marks obtained by the students of the class.

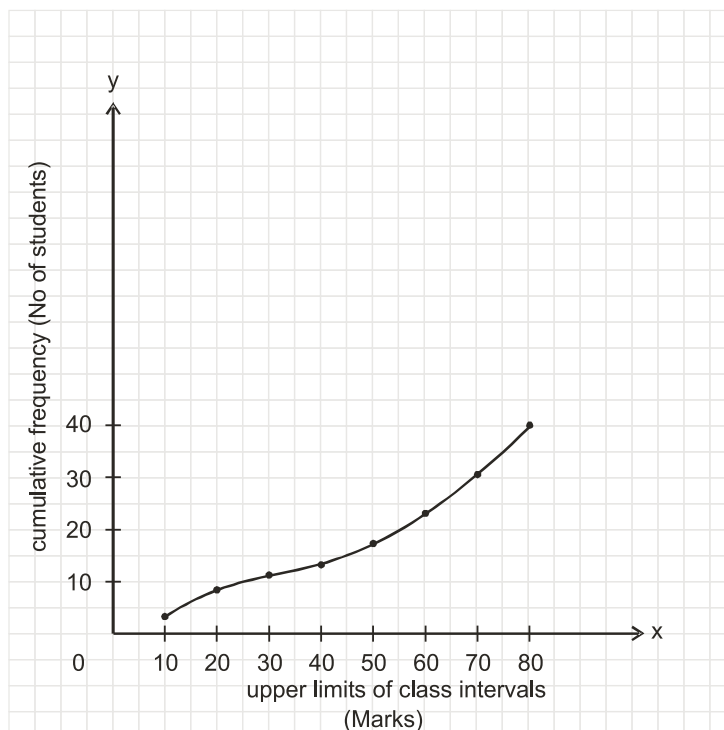

## Section B

- 11 Without drawing the graphs, state whether the following pair of linear equations will represent intersecting lines, coincident lines or parallel lines :

$$6x - 3y + 10 = 0$$

$$2x - y + 9 = 0$$

Justify your answer.

12. Without using trigonometric tables, find the value of  $\frac{\cos 70^\circ}{\sin 20^\circ} + \cos 57^\circ \operatorname{cosec} 33^\circ - 2 \cos 60^\circ$

- 13 Find a point on the y-axis which is equidistant from the points A(6,5) and B (-4,3).

- 14 In the figure given below, AC is parallel to BD,

Is  $\frac{AE}{CE} = \frac{DE}{BE}$  ? Justify your answer.

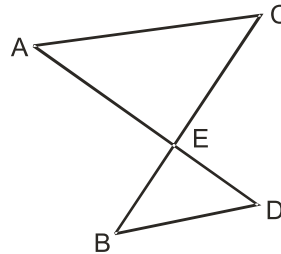

15. A bag contains 5 red, 8 green and 7 white balls. One ball is drawn at random from the bag, find the probability of getting
- a white ball or a green ball.
  - neither a green ball nor a red ball.

OR

One card is drawn from a well shuffled deck of 52 playing cards. Find the probability of getting

- a non-face card
- A black king or a red queen.

## Section C

- 16 Using Euclid's division algorithm, find the HCF of 56, 96 and 404.

OR

Prove that  $3 - \sqrt{5}$  is an irrational number

17. If two zeroes of the polynomial  $x^4 + 3x^3 - 20x^2 - 6x + 36$  are  $\sqrt{2}$  and  $-\sqrt{2}$ , find the other zeroes of the polynomial.
18. Draw the graph of the following pair of linear equations

$$x + 3y = 6$$

$$2x - 3y = 12$$

Hence find the area of the region bounded by the

$$x = 0, y = 0 \text{ and } 2x - 3y = 12$$

19. A contract on construction job specifies a penalty for delay of completion beyond a certain date as follows: Rs 200 for 1st day, Rs. 250 for second day, Rs. 300 for third day and so on. If the contractor pays Rs 27750 as penalty, find the number of days for which the construction work is delayed.

20. Prove that:  $\frac{1 + \cos A}{\sin A} + \frac{\sin A}{1 + \cos A} = 2 \operatorname{cosec} A$

OR

Prove that:

$$\frac{\sin A + \cos A}{\sin A - \cos A} + \frac{\sin A - \cos A}{\sin A + \cos A} = \frac{2}{\sin^2 A - \cos^2 A}$$

21. Observe the graph given below and state whether triangle ABC is scalene, isosceles or equilateral. Justify your answer. Also find its area.

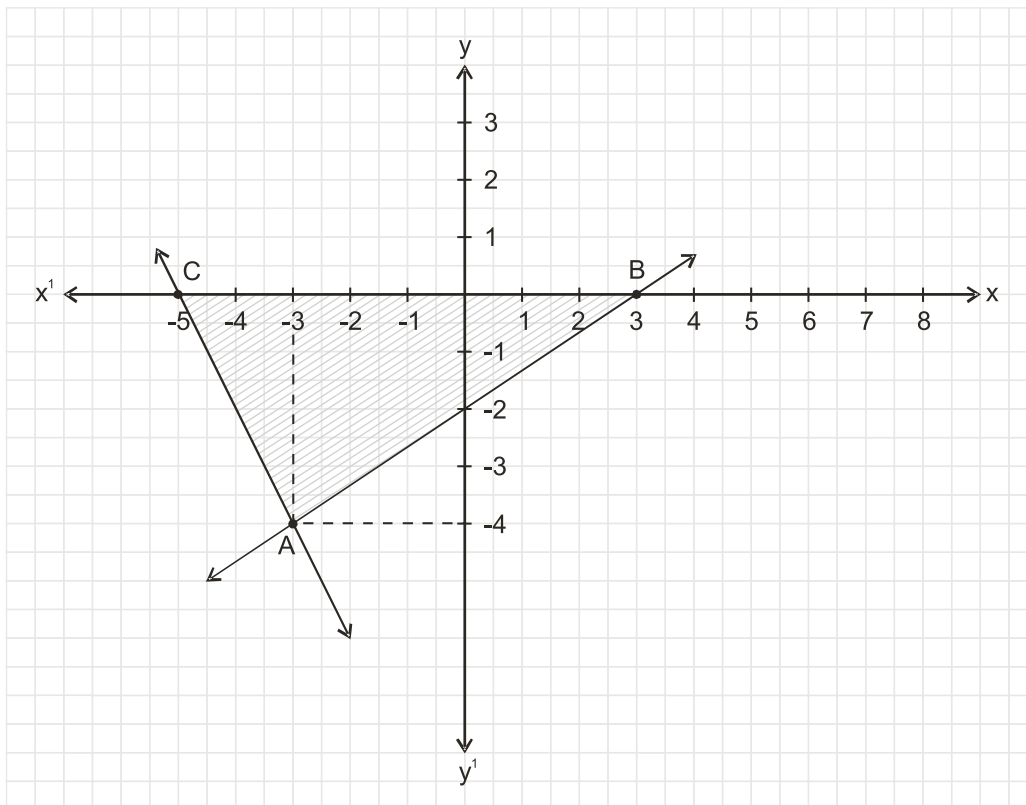

22. Find the area of the quadrilateral whose vertices taken in order are A (-5,-3) B(-4, -6), C(2,-1) and D (1,2).
23. Construct a  $\triangle ABC$  in which  $CA = 6\text{cm}$ ,  $AB = 5\text{cm}$  and  $\angle BAC = 45^\circ$ , then construct a triangle similar to the given triangle whose sides are  $\frac{6}{5}$  of the corresponding sides of the  $\triangle ABC$ .
24. Prove that the intercept of a tangent between two parallel tangents to a circle subtends a right angle at the centre of the circle.
25. A square field and an equilateral triangular park have equal perimeters. If the cost of ploughing the field at rate of Rs 5/  $\text{m}^2$  is Rs 720, find the cost of maintaining the park at the rate of Rs 10/ $\text{m}^2$ .

OR

An iron solid sphere of radius 3cm is melted and recast into small spherical balls of radius 1cm each. Assuming that there is no wastage in the process, find the number of small spherical balls made from the given sphere.

#### Section D

26. Some students arranged a picnic. The budget for food was Rs 240. Because four students of the group failed to go, the cost of food to each student got increased by Rs 5. How many students went for the picnic?

OR

A plane left 30 minutes late than its scheduled time and in order to reach the destination 1500km away in time, it had to increase the speed by 250 km/h from the usual speed. Find its usual speed.

27. From the top of a building 100 m high, the angles of depression of the top and bottom of a tower are observed to be  $45^\circ$  and  $60^\circ$  respectively. Find the height of the tower. Also find the distance between the foot of the building and bottom of the tower.

OR

The angle of elevation of the top a tower at a point on the level ground is  $30^\circ$ . After walking a distance of 100m towards the foot of the tower along the horizontal line through the foot of the tower on the same level ground, the angle of elevation of the top of the tower is  $60^\circ$ . Find the height of the tower.

28. Prove that in a right triangle, the square of the hypotenuse is equal to the sum of the squares of the other two sides.

Using the above, solve the following:

A ladder reaches a window which is 12m above the ground on one side of the street. Keeping its foot at the same point, the ladder is turned to the other side of the street to reach a window 9m high. Find the width of the street if the length of the ladder is 15m.

29. The interior of building is in the form of a right circular cylinder of radius 7m and height 6m, surmounted by a right circular cone of same radius and of vertical angle  $60^\circ$ . Find the cost of painting the building from inside at the rate of Rs 30/m<sup>2</sup>
- 30 The following table shows the marks obtained by 100 students of class X in a school during a particular academic session. Find the mode of this distribution.

Marks	No. of students
Less than 10	7
Less than 20	21
Less than 30	34
Less than 40	46
Less than 50	66
Less than 60	77
Less than 70	92
Less than 80	100

**Marking Scheme**  
**Sample Question Paper I**  
**X- Mathematics**

Q.No.	Value points	Marks
<b>Section A</b>		
1	q should be expressible as $2^x \cdot 5^y$ where x, y are whole numbers	1
2	$2x^2 + x - 6$	1
3	$\pm 4$	1
4	$\frac{2}{3}$	1
5	$24^{\text{th}}$	1
6	$3 : 1 : 2$	1
7	$9 : 1$	1
8	8 cm.	1
9	0	1
10	55.	1
<b>Section B</b>		
11	<p style="text-align: center;">Parallel lines</p> <p>Here <math>\frac{a_1}{a_2} = 3, \frac{b_1}{b_2} = 3, \frac{c_1}{c_2} = \frac{10}{9}</math></p> <p style="text-align: center;"><math>\frac{a_1}{a_2} = \frac{b_1}{b_2} \neq \frac{c_1}{c_2}</math></p> <p>Given system of equations will represent parallel lines.</p>	<p style="text-align: center;"><math>\frac{1}{2}</math></p> <p style="text-align: center;"><math>\frac{1}{2}</math></p> <p style="text-align: center;"><math>\frac{1}{2}</math></p> <p style="text-align: center;"><math>\frac{1}{2}</math></p>
12.	<p style="text-align: center;"><math>\cos 70^\circ = \sin (90^\circ - 70^\circ) = \sin 20^\circ</math></p> <p><math>\cos 57^\circ = \sin (90^\circ - 57^\circ) = \sin 33^\circ</math></p> <p><math>\cos 60^\circ = \frac{1}{2}</math></p> <p><math>\frac{\cos 70^\circ}{\sin 20^\circ} + \cos 57^\circ \operatorname{cosec} 33^\circ - 2 \cos 60^\circ</math></p>	<p style="text-align: center;"><math>\frac{1}{2}</math></p> <p style="text-align: center;"><math>\frac{1}{2}</math></p>

Q .No	Value Points	Marks
	$\frac{\sin 20^\circ}{\sin 20^\circ} + \sin 33^\circ \operatorname{cosec} 33^\circ - 2 \times \frac{1}{2}$ $= 1 + 1 - 1 = 1$	<p>1/2</p> <p>1/2</p>
13.	<p>Let (0,y) be a point on the y-axis, equidistant from A (6,5) and B (-4,3)</p> $PA = \sqrt{y^2 - 10y + 61}$ $PB = \sqrt{y^2 - 6y + 25}$ <p>Now, PA = PB <math>\Rightarrow</math> (PA)<sup>2</sup> = (PB)<sup>2</sup>  i.e. <math>y^2 - 10y + 61 = y^2 - 6y + 25</math>  <math>\Rightarrow y = 9,</math>  Required point is (0,9).</p>	<p>1/2</p> <p>1</p> <p>1/2</p>
14	<p>Yes</p> <p><math>\triangle ACE \sim \triangle DBE</math> (AA similarity)</p> $\frac{AC}{BD} = \frac{CE}{BE} = \frac{AE}{DE}$ $\frac{AE}{CE} = \frac{DE}{BE}$	<p>1/2</p> <p>1</p> <p>1/2</p>
15	<p>(i) P (White or green ball) = <math>\frac{15}{20} = \frac{3}{4}</math></p> <p>(ii) P (Neither green nor red) = <math>\frac{7}{20}</math></p> <p>OR</p> <p>(i) P (non-face card) = <math>\frac{40}{52} = \frac{10}{13}</math></p> <p>(ii) P (black king or red queen) = <math>\frac{4}{52} = \frac{1}{13}</math></p>	<p>1</p> <p>1</p> <p>1</p> <p>1</p>

Q.No	Value Points	Marks
16	<b>Section C</b>	
	Using Euclid's division algorithm we have.	
	$96 = 56 \times 1 + 40$	
	$56 = 40 \times 1 + 16$	
	$40 = 16 \times 2 + 8$	
	$16 = 8 \times 2 + 0 \therefore$ HCF of 56 and 96 is 8.	2
	Now to find HCF of 56, 96 and 404 we apply Euclid's division algorithm to 404 and 8 i.e.	
	$404 = 8 \times 50 + 4$	
	$8 = 4 \times 2 + 0 \therefore$ 4 is the required HCF	1
	OR	
	Let $3 - \sqrt{5}$ be a rational number, say x	
	$\therefore 3 - \sqrt{5} = x$	
	$\Rightarrow \sqrt{5} = 3 - x$	$\frac{1}{2}$
	Here R.H.S is a rational number, as both 3 and x are so	
	$\Rightarrow \sqrt{5}$ is a rational number	$\frac{1}{2}$
	proving that $\sqrt{5}$ is not rational	$1\frac{1}{2}$
	$\therefore$ Our supposition is wrong	
	$\Rightarrow 3 - \sqrt{5}$ is an irrational number	$\frac{1}{2}$
17.	<p>Since <math>\sqrt{2}</math> and <math>-\sqrt{2}</math> are two zeroes of the polynomial  <math>\therefore (x - \sqrt{2})(x + \sqrt{2})</math> is a factor of the polynomial.</p> <p>By long division method</p> $x^4 + 3x^3 - 20x^2 - 6x + 36 = (x^2 - 2)(x^2 + 3x - 18)$ $= (x^2 - 2)(x + 6)(x - 3)$ <p><math>\therefore</math> The other zeroes of the Polynomial are -6,3.</p>	1
		1
		1

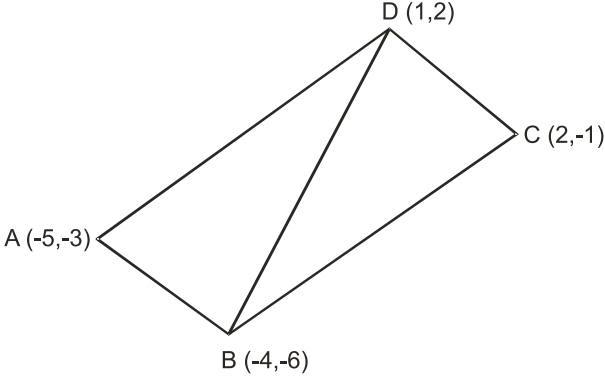

Q.No	Value Points	Marks
	<p>OR</p> $\text{LHS} = \frac{(\sin A + \cos A)^2 + (\sin A - \cos A)^2}{(\sin A - \cos A)(\sin A + \cos A)}$ $= \frac{\sin^2 A + \cos^2 A + 2\sin A \cos A + \sin^2 A + \cos^2 A - 2\sin A \cos A}{\sin^2 A - \cos^2 A}$ $= \frac{2}{\sin^2 A - \cos^2 A} = \text{RHS.}$	<p>1</p> <p>1</p> <p>1</p>
21	<p>Scalene.</p> <p>Justification: Coordinates of A,B and C are respectively (-3, -4), (3,0), (-5,0).</p> $AB = \sqrt{52}$ $BC = \sqrt{8}$ $CA = \sqrt{20}$ <p>Clearly <math>AB \neq BC \neq CA \therefore</math> the given triangle is scalene.</p> <p>Area = <math>\frac{1}{2}</math> BC x (<math>\perp</math> from A on BC)</p> <p>= <math>\frac{1}{2}</math> (8x4) = 16 sq•u.</p>	<p>1</p> <p><math>\frac{1}{2}</math></p> <p><math>\frac{1}{2}</math></p> <p>1</p>
22.	 <p>Area of quad ABCD = area <math>\triangle</math> ABD + area <math>\triangle</math> BCD.</p> <p>area <math>\triangle</math> ABD = <math>\frac{1}{2}</math> [-5 (-6-2) - 4 (2+3) + (-3+6)].</p> $= \frac{23}{2} \text{ sq•u.}$ <p>Area <math>\triangle</math> BCD = <math>\frac{1}{2}</math> [-4 (-1-2) + 2 (2+6) + 1 (-6+1)]</p>	<p><math>\frac{1}{2}</math></p> <p>1</p>

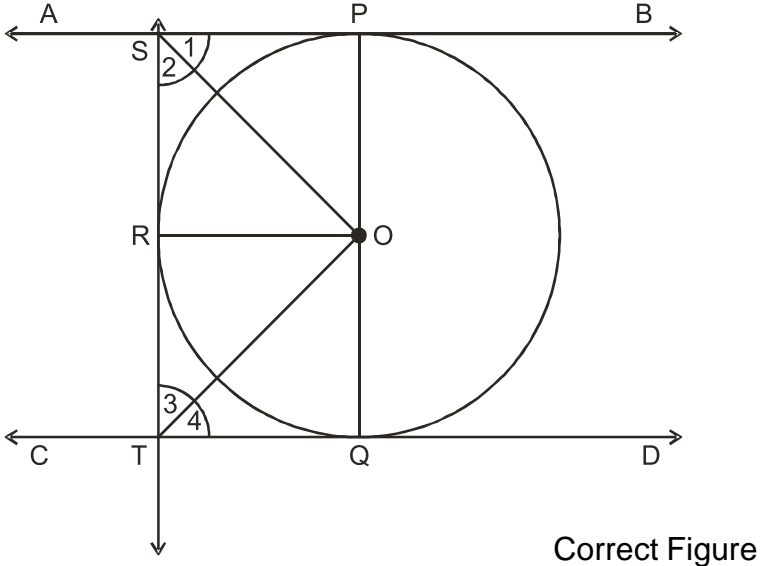
Q.No	Value Points	Marks
	$= \frac{23}{2} \text{ sq}\cdot\text{u.}$ $\text{Area of quad ABCD} = \left( \frac{23}{2} + \frac{23}{2} \right) = 23 \text{ sq}\cdot\text{u.}$	<p>1</p> <p><math>\frac{1}{2}</math></p>
23.	<p>For construction of <math>\Delta ABC</math></p> <p>For constructio of the required similar triangle</p>	<p>1</p> <p>2</p>
24.	<div style="text-align: center;">  </div> <p>Since tangent is perpendicular to the radius :</p> $\angle SPO = \angle SRO = \angle OQT = 90^\circ$ <p>In right triangles OPS and ORS</p> <p>OS = OS (Common)</p> <p>OP = OR (radii of circle)</p> <p><math>\therefore \Delta OPS \cong \Delta ORS</math> (RHS Congruence)</p> <p><math>\therefore \angle 1 = \angle 2</math></p> <p>Similarly <math>\angle 3 = \angle 4</math></p> <p>Now <math>\angle 1 + \angle 2 + \angle 3 + \angle 4 = 180^\circ</math> (Sum of angles on the same side of Iranversal)</p> <p><math>\Rightarrow \angle 2 + \angle 3 = 90^\circ</math></p> <p><math>\therefore \angle SOT = 90^\circ</math></p>	<p><math>\frac{1}{2}</math></p> <p>1</p> <p><math>\frac{1}{2}</math></p> <p><math>\frac{1}{2}</math></p> <p><math>\frac{1}{2}</math></p>
25.	Let the side of the square be 'a' meters	

Q.No	Value Points	Marks
	<p><math>5 \times a^2 = 720 \Rightarrow a = 12\text{m.}</math></p> <p><math>\therefore</math> Perimeter of square = 48 m.</p> <p><math>\Rightarrow</math> Perimeter of triangle = 48m.</p> <p><math>\Rightarrow</math> Side of triangle = 16m.</p> <p>Now Area of triangle = <math>\frac{\sqrt{3}}{4} \times 16 \times 16</math></p> <p style="padding-left: 40px;"><math>= 64 \sqrt{3} \text{ m}^2.</math></p> <p>Cost of maintaining the park</p> <p style="padding-left: 40px;"><math>= \text{Rs. } (10 \times 64 \sqrt{3})</math></p> <p style="padding-left: 40px;"><math>= \text{Rs. } (640 \sqrt{3}).</math></p> <p style="text-align: center;">OR</p> <p>radius of sphere = 3cm.</p> <p>Volume of sphere = <math>\frac{4}{3} \pi \times 3 \times 3 \times 3</math></p> <p style="padding-left: 40px;"><math>= 36 \pi \text{ cm}^3</math></p> <p>radius of spherical ball = 1 cm.</p> <p>Volume of one spherical ball = <math>\frac{4}{3} \pi \times 1 \times 1 \times 1</math></p> <p style="padding-left: 40px;"><math>\frac{4\pi}{3} \text{ cm}^3</math></p> <p>Let the number of small spherical balls be N.</p> <p><math>\left(\frac{4\pi}{3}\right) \times N = 36 \pi</math></p> <p><math>\Rightarrow N = 27</math></p>	<p><math>\frac{1}{2}</math></p> <p><math>\frac{1}{2}</math></p> <p><math>\frac{1}{2}</math></p> <p>1</p> <p><math>\frac{1}{2}</math></p> <p></p> <p>1</p> <p><math>\frac{1}{2}</math></p> <p>1</p> <p><math>\frac{1}{2}</math></p>
26.	<p style="text-align: center;"><b>Section D</b></p> <p>Let the number of students who arranged the picnic be x.</p> <p><math>\therefore</math> Cost of food for one student = <math>\frac{240}{x}</math></p> <p>New cost of food for one student = <math>\frac{240}{x-4}</math></p>	<p></p> <p>1</p> <p><math>\frac{1}{2}</math></p>

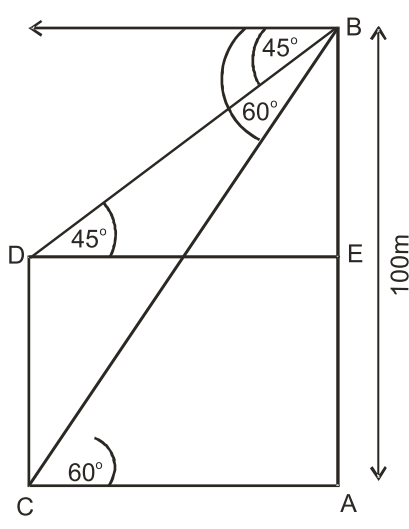
Q.No	Value Points	Marks
	$\frac{240}{x-4} - \frac{240}{x} = 5$ $\Rightarrow x^2 - 4x - 192 = 0$ $\Rightarrow (x - 16)(x + 12) = 0$ $\Rightarrow x = 16 \text{ or } x = -12 \text{ (Rejected)}$ <p>No of students who actually went for the picnic = <math>16 - 4 = 12</math></p> <p style="text-align: center;">OR</p> <p>Let the usual speed of plane be <math>x</math> km/hour</p> <p>Time taken = <math>\left(\frac{1500}{x}\right)</math> hrs. with usual speed</p> <p>Time taken after increasing speed = <math>\left(\frac{1500}{x+250}\right)</math> hrs</p> $\frac{1500}{x} - \frac{1500}{x+250} = \frac{1}{2}$ $\Rightarrow x^2 + 250x - 750000 = 0$ $\Rightarrow (x + 1000)(x - 750) = 0$ $\Rightarrow x = 750 \text{ or } -1000 \text{ (Rejected)}$ <p><math>\therefore</math> usual speed of plane = 750km/h.</p>	<p>1½</p> <p>1</p> <p>1</p> <p>½</p> <p>½</p> <p>1</p> <p>½</p> <p>1½</p> <p>1</p> <p>1</p> <p>½</p> <p>½</p>
27.	 <p style="text-align: center;">Correct Figure</p> <p>In right <math>\triangle BAC</math>, <math>\frac{AB}{AC} = \tan 60^\circ</math></p> $\frac{100}{AC} = \tan 60^\circ$ $\Rightarrow AC = \left(\frac{100}{\sqrt{3}}\right) \text{ m.}$	<p>1</p> <p>1½</p>

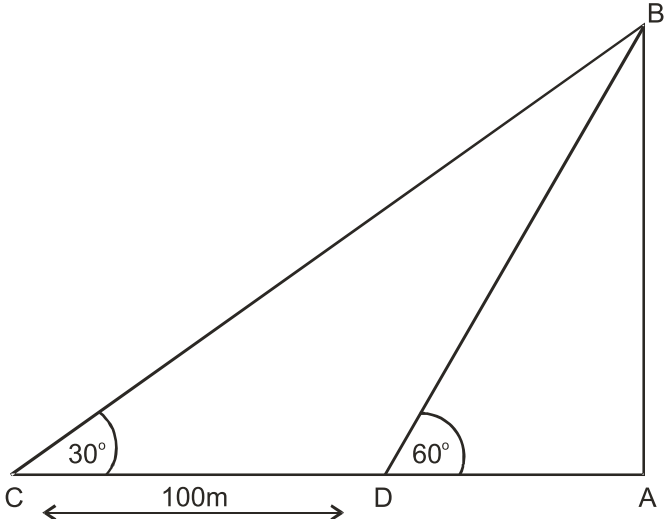
Q.No	Value Points	Marks
	<p>In right <math>\triangle BED</math>, <math>\frac{BE}{DE} = \tan 45^\circ = 1</math></p> <p><math>BE = DE</math></p> <p><math>\therefore BE = \left(\frac{100}{\sqrt{3}}\right) \text{ m.}</math></p> <p>Height of tower (CD) = AE</p> <p><math>= AB - BE</math></p> <p><math>= \left(100 - \frac{100}{\sqrt{3}}\right) \text{ m.}</math></p> <p><math>= 42.27 \text{ m.}</math></p> <p>Distance between the foot the building and the bottom of the tower (AC) = 57.73 m.</p> <p style="text-align: center;">OR</p> <div style="text-align: center;">  <p style="text-align: center;">Correct figure</p> </div> <p>In right <math>\triangle BAC</math>, <math>\frac{AB}{AC} = \tan 30^\circ</math></p> <p><math>AB = (100 + AD) \times \frac{1}{\sqrt{3}}</math> (i)</p> <p>In right <math>\triangle BAD</math>,</p> <p><math>\frac{AB}{AD} = \tan 60^\circ</math></p> <p><math>AB = AD \times \sqrt{3}</math> (ii)</p> <p>From (i) and (ii) we get</p>	<p style="text-align: center;">1½</p> <p style="text-align: center;">1</p> <p style="text-align: center;">½</p> <p style="text-align: center;">½</p> <p style="text-align: center;">1</p> <p style="text-align: center;">1½</p> <p style="text-align: center;">1½</p>

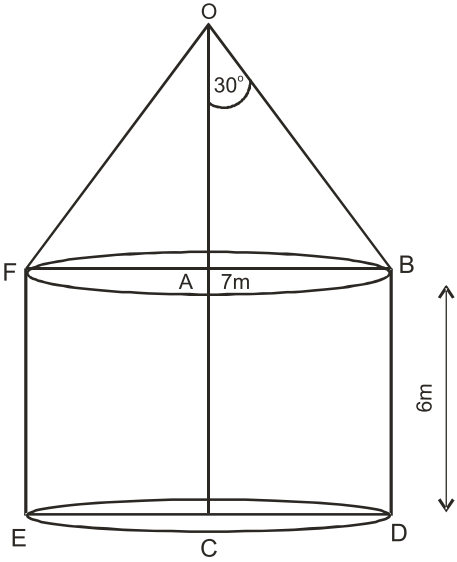
Q.No	Value Points	Marks
	$\frac{100 + AD}{\sqrt{3}} = AD \times \sqrt{3}$ $100 + AD = 3AD$ $\Rightarrow AD = 50 \text{ m}$ <p>From (ii) <math>AB = 50\sqrt{3} \text{ m}</math></p> $= 50 \times 1.732 \text{ m}$ <p>or, <math>AB = 86.6 \text{ m}</math>.</p>	<p>1½</p> <p>1½</p>
28.	<p>Fig, Given, To Prove, Construction</p> <p>Proof</p> <p>2nd part of the question:</p> <p><math>AE = 9\text{m}</math>.</p> <p><math>CE = 12\text{m}</math>.</p> <p>width of street = 21 m.</p>	<p>½ x 4 =</p> <p>2</p> <p>2</p> <p>1</p> <p>½</p> <p>½</p>
29.	 <p>Correct Figure.</p> <p>Internal curved surface area of cylinder</p> $= 2\pi rh.$ $= (2\pi \times 7 \times 6) \text{ m}^2$ $= (2 \times \frac{22}{7} \times 7 \times 6) \text{ m}^2$ $= 264 \text{ m}^2$	<p>1</p> <p>1½</p>

Q.No	Value Points	Marks																		
	<p>In right <math>\triangle OAB</math>, <math>\frac{AB}{OB} = \sin 30^\circ</math></p> $\frac{7}{OB} = \frac{1}{2}$ <p><math>\therefore</math> Slant height of cone (OB) = 14m.</p> <p>Internal curved surface area of cone</p> $= \pi r l$ $= \frac{22}{7} \times 7 \times 14$ $= 308 \text{m}^2.$ <p>Total Area to be painted = (264 + 308)</p> $= 572 \text{m}^2.$ <p>Cost of painting = Rs (30 x 572)</p> $= \text{Rs } 17160.$	<p>1</p> <p>1</p> <p>1</p> <p><math>\frac{1}{2}</math></p>																		
30	<p>The given data can be written as -</p> <table style="margin-left: auto; margin-right: auto;"> <thead> <tr> <th>Marks</th> <th>No of students</th> </tr> </thead> <tbody> <tr> <td>0 - 10</td> <td>7</td> </tr> <tr> <td>10 - 20</td> <td>14</td> </tr> <tr> <td>20 - 30</td> <td>13</td> </tr> <tr> <td>30 - 40</td> <td>12</td> </tr> <tr> <td>40 - 50</td> <td>20</td> </tr> <tr> <td>80 - 60</td> <td>11</td> </tr> <tr> <td>60 - 70</td> <td>15</td> </tr> <tr> <td>70 - 80</td> <td>8</td> </tr> </tbody> </table>	Marks	No of students	0 - 10	7	10 - 20	14	20 - 30	13	30 - 40	12	40 - 50	20	80 - 60	11	60 - 70	15	70 - 80	8	<p>1</p>
Marks	No of students																			
0 - 10	7																			
10 - 20	14																			
20 - 30	13																			
30 - 40	12																			
40 - 50	20																			
80 - 60	11																			
60 - 70	15																			
70 - 80	8																			

$$\text{Mode} = l + \left( \frac{f_1 - f_0}{2f_1 - f_0 - f_2} \right) \times h$$

1

Here Modal class is 40 - 50

1

$$\therefore \text{Mode} = 40 + \frac{(20-12)}{(2 \times 20 - 12 - 11)} \times 10$$

2

$$= 40 + \frac{80}{17}$$

$$= 44.7$$

1