

DESIGN OF THE QUESTION PAPER
PHYSICS - CLASS XII

Time : 3 Hrs.

Max. Marks : 70

The weightage of the distribution of marks over different dimensions of the question paper shall be as follows:

A. Weightage to content/ subject units

<u>Unit</u>	<u>Marks</u>
Electrostatics	08
Current Electricity	07
Magnetic Effect of Current & Magnetism	08
Electromagnetic Induction and Alternating current	08
Electromagnetic Waves	03
Optics	14
Dual Nature of Matter	04
Atoms and Nuclei	06
Electronic Devices	07
Communication Systems	05
Total	70

B. Weightage to form of questions

S.No.	Form of Questions	Marks for each Question	No. of Questions	Total Marks
1.	Long Answer Type (LA)	5	3	15
2.	Short Answer (SA I)	3	09	27
3.	Short Answer (SA II)	2	10	20
4.	Very Short Answer (VSA)	1	08	08
	TOTAL	-	30	70

C. Scheme of Options

1. There will be no overall option.
2. Internal choices (either / or type) on a very selective basis has been given in five questions. This internal choice is given in any one question of 2 marks, any one question of 3 marks and all three questions of 5 marks weightage.

D. A Weightage of about 15 marks in total, has been assigned to numericals

E. Weightage to difficulty level of questions.

<u>S.No.</u>	<u>Estimated difficulty level</u>	<u>Percentage</u>
1.	Easy	15
2.	Average	70
3.	Difficult	15

A weightage of 20% has been assigned to questions which test higher order thinking skills of students.

**BLUE PRINT - III
XII - PHYSICS**

Topic	VSA (1 mark)	SA I (2 marks)	SA II (3 marks)	LA (5 marks)	Total
Electrostatics	1(1)	2(1)	-	5(1)	8(3)
Current Electricity	-	4(2)	3(1)	-	7(3)
Magnetic effect & Magnetism	1(1)	2(1)	-	5(1)	8(3)
Electromagnetic induction & Alternating currents	1(1)	4(2)	3(1)	-	8(4)
Electromagnetic Waves	1(1)	2(1)	-	-	3(2)
Optics	1(1)	2(1)	6(2)	5(1)	14(5)
Dual Nature of Matter	1(1)	-	3(1)	-	4(2)
Atoms & Nuclei	-	-	6 (2)	-	6(2)
Electronic Devices	2(2)	2(1)	3(1)	-	7(4)
Communication Systems	-	2(1)	3(1)	-	5(2)
Total	8(8)	20(10)	27(9)	15(3)	70(30)

(112)

SAMPLE PAPER III
XII - PHYSICS

Time : Three Hours

Max. Marks : 70

General Instructions :

- (a) All questions are compulsory.
- (b) There are 30 questions in total. Questions 1 to 8 carry one mark each, questions 9 to 18 carry two marks each, questions 19 to 27 carry three marks each and questions 28 to 30 carry five marks each.
- (c) There is no over all choice. However, an internal choice has been provided in one question of two marks, one question of three marks and all three questions of five marks each. You have to attempt only one of the given choices in such questions.
- (d) Use of calculators is not permitted.
- (e) You may use the following physical constants wherever necessary :

$$\begin{aligned}c &= 3 \times 10^8 \text{ms}^{-1} \\h &= 6.6 \times 10^{-34} \text{Js} \\e &= 1.6 \times 10^{-19} \text{C} \\ \mu_0 &= 4\pi \times 10^{-7} \text{T m A}^{-1}\end{aligned}$$

$$\begin{aligned}\text{Boltzmann constant } k &= 1.38 \times 10^{23} \text{JK}^{-1} \\ \text{Avogadro's number } N_A &= 6.023 \times 10^{23} / \text{mole} \\ \text{Mass of neutron } m_n &= 1.6 \times 10^{-27} \text{kg} \\ \text{Mass of electron } m_e &= 9 \times 10^{-31} \text{kg}\end{aligned}$$

1. The graph shown here, shows the variation of the total energy (E) stored in a capacitor against the value of the capacitance(C) itself. Which of the two - the charge on the capacitor or the potential used to charge it is kept constant for this graph?

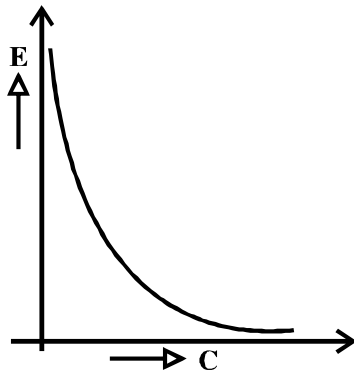

1

2. An α - particle and a proton are moving in the plane of the paper in a region where there is a uniform magnetic field (\vec{B}) directed normal to the plane of the paper. If the two particles have equal linear momenta, what will be the ratio of the radii of their trajectories in the field?

1

3. State the condition under which a microwave oven heats up a food item containing water molecules most efficiently.

1

4. An electrical element X, when connected to an alternating voltage source, has the current through it leading the voltage by $\frac{\pi}{2}$ radians. Identify X and write an expression for its reactance. 1
5. A double convex lens, made from a material of refractive index μ_1 , is immersed in a liquid of refractive index μ_2 where $\mu_2 > \mu_1$. What change, if any, would occur in the nature of the lens? 1
6. The de Broglie wavelengths, associated with a proton and a neutron, are found to be equal. Which of the two has a higher value for kinetic energy? 1
7. Carbon and silicon are known to have similar lattice structures. However, the four bonding electrons of carbon are present in second orbit while those of silicon are present in its third orbit. How does this difference result in a difference in their electrical conductivities? 1
8. An unknown input (A) and the input (B) shown here, are used as the two inputs in a NAND gate. The output Y, has the form shown below. Identify the intervals over which the input 'A' must be 'low'. 1

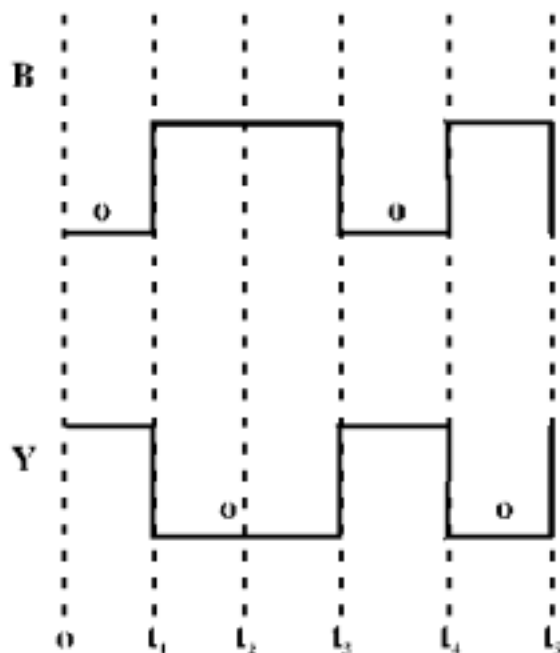

9. The two graphs drawn below, show the variation of electrostatic potential (V) with $\frac{1}{r}$ (r being distance of the field point from the point charge) for two point charges q_1 and q_2 .

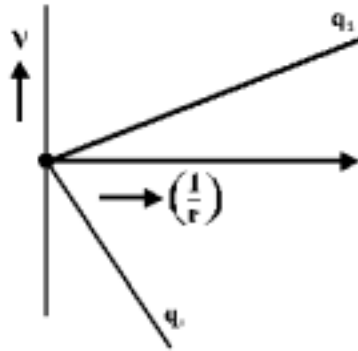

(i) What are the signs of the two charges?

(ii) Which of the two charges has a larger magnitude and why?

2

10. Calculate the temperature at which the resistance of a conductor becomes 20% more than its resistance at 27°C . The value of the temperature coefficient of resistance of the conductor is $2.0 \times 10^{-4} / \text{K}$.

2

11. A student records the following data for the magnitudes (B) of the magnetic field at axial points at different distances x from the centre of a circular coil of radius a carrying a current I . Verify (for any two) that these observations are in good agreement with the expected theoretical variation of B with x .

$x \rightarrow$	$x = 0$	$x = a$	$x = 2a$	$x = 3a$
$B \rightarrow$	B_0	$0.25\sqrt{2}B_0$	$0.039\sqrt{5}B_0$	$0.010\sqrt{10}B_0$

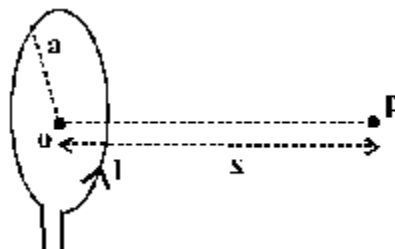

2

12. An armature coil consists of 20 turns of wire, each of area $A = 0.09\text{m}^2$ and total resistance 15.0Ω . It rotates in a magnetic field of 0.5T at a constant frequency of $\frac{150}{\pi} \text{Hz}$. Calculate the value of (i) maximum (ii) average induced emf produced in the coil

2

13. Two cells of emf E_1 and E_2 have internal resistance r_1 and r_2 . Deduce an expression for equivalent emf of their parallel combination.

OR

A cell of emf (E) and internal resistance (r) is connected across a variable external resistance (R). Plot graphs to show variation of

(i) E with R ,

(ii) Terminal p.d. of the cell (V) with R

2

14. Fig. shows a light bulb (B) and iron cored inductor connected to a DC battery through a switch (S).

2

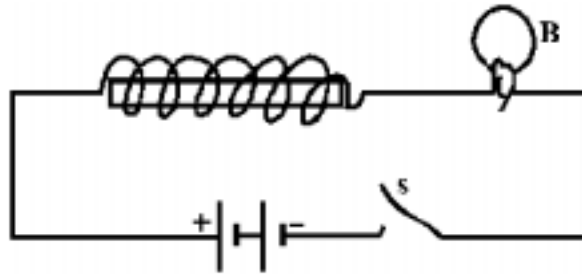

(i) What will one observe when switch (S) is closed?

(ii) How will the glow of the bulb change when the battery is replaced by an ac source of rms voltage equal to the voltage of DC battery? Justify your answer in each case.

15. Electromagnetic radiations with wavelength

2

(i) λ_1 are used to kill germs in water purifiers.

(ii) λ_2 are used in TV communication systems

(iii) λ_3 play an important role in maintaining the earth's warmth.

Name the part of electromagnetic spectrum to which these radiations belong. Arrange these wavelengths in decreasing order of their magnitude.

16. What do the terms 'depletion region' and 'barrier potential' mean for a p-n junction?

2

17. We do not choose to transmit an audio signal by just directly converting it to an e.m. wave of the same frequency. Give two reasons for the same.

2

18. Light of wavelength 550 nm. is incident as parallel beam on a slit of width 0.1mm. Find the angular width and the linear width of the principal maxima in the resulting diffraction pattern on a screen kept at a distance of 1.1m from the slit. Which of these widths would not change if the screen were moved to a distance of 2.2m from the slit?

2

19. The given figure shows the experimental set up of a metre bridge. The null point is found to be 60cm away from the end A with X and Y in position as shown.

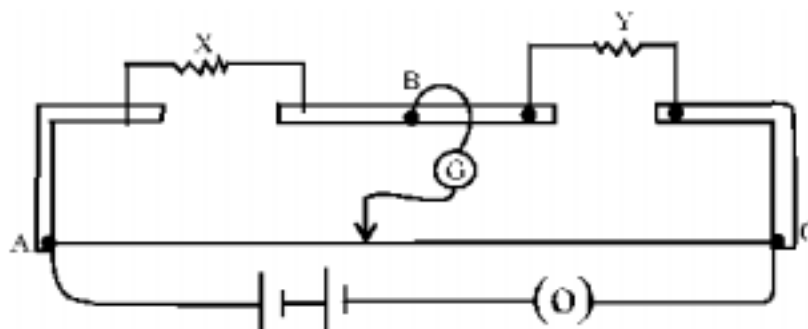

When a resistance of $15\ \Omega$ is connected in series with 'Y', the null point is found to shift by 10cm towards the end A of the wire. Find the position of null point if a resistance of $30\ \Omega$ were connected in parallel with 'Y'. 3

OR

Why is a potentiometer preferred over a voltmeter for determining the emf of a cell?

Two cells of Emf E_1 and E_2 are connected together in two ways shown here.



The 'balance points' in a given potentiometer experiment for these two combinations of cells are found to be at 351.0cm and 70.2cm respectively. Calculate the ratio of the Emfs of the two cells.

20. When a circuit element 'X' is connected across an a.c. source, a current of $\sqrt{2}$ A flows through it and this current is in phase with the applied voltage. When another element 'Y' is connected across the same a.c. source, the same current flows in the circuit but it leads the voltage by $\frac{\pi}{2}$ radians.

(i) Name the circuit elements X and Y.

(ii) Find the current that flows in the circuit when the series combination of X and Y is connected across the same a.c. voltage.

(iii) Plot a graph showing variation of the net impedance of this series combination of X and Y as a function of the angular frequency ω of the applied voltage. 3

21. Give reasons for the following : 3

(a) Astronomers prefer to use telescopes with large objective diameters to observe astronomical objects.

(b) Two identical but independent monochromatic sources of light cannot be coherent.

(c) The value of the Brewster angle for a transparent medium is different for lights of different colours.

22. The given graphs show the variation of the stopping potential V_s with the frequency (ν) of the incident radiations for two different photosensitive materials M_1 and M_2 .

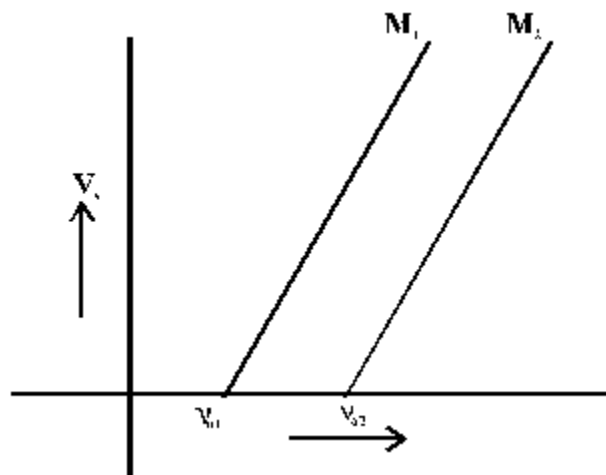

(i) What are the values of work functions for M_1 and M_2 ?

(ii) The values of the stopping potential for M_1 and M_2 for a frequency $\nu_3 (> \nu_{02})$ of the incident radiations are V_1 and V_2

respectively. Show that the slope of the lines equals $\frac{V_1 - V_2}{\nu_{02} - \nu_{01}}$ 3

23. What is a wavefront? Distinguish between a plane wavefront and a spherical wavefront. Explain with the help of a diagram, the refraction of a plane wavefront at a plane surface using Huygen's construction. 3

24. Define the term 'Activity' of a radioactive substance. State its SI unit.

Two different radioactive elements with half lives T_1 and T_2 have N_1 and N_2 (undecayed) atoms respectively present at a given instant. Determine the ratio of their activities at this instant. 3

25. (a) Draw the block diagram of a communication system.

(b) What is meant by 'detection' of a modulated carrier wave? Describe briefly the essential steps for detection. 3

26. The given circuit diagram shows a transistor configuration along with its output characteristics. Identify

- (i) the type of transistor used and
- (ii) the transistor configuration employed.

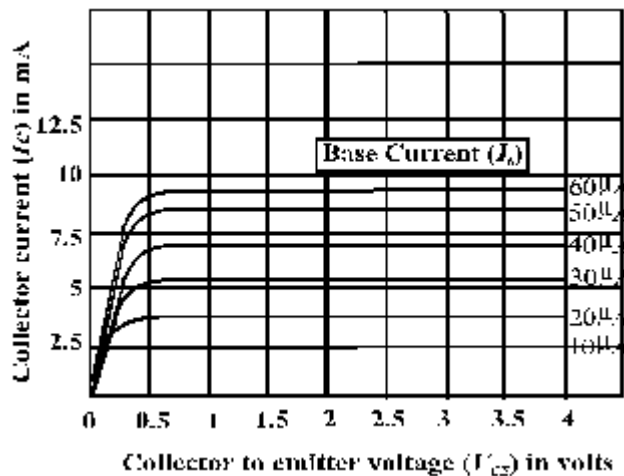
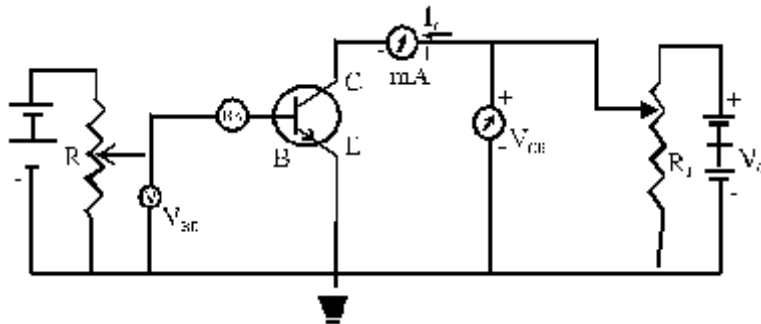

Use these graphs to obtain the approximate value of current amplification factor for the transistor at $V_{CE} = 3V$. 3

27. State Bohr's postulate for the 'permitted orbits' for the electron in a hydrogen atom.

Use this postulate to prove that the circumference of the n^{th} permitted orbit for the electron can 'contain' exactly n wave lengths of the deBroglie wavelength associated with the electron in that orbit. 3

28. Obtain an expression for the capacitance of a parallel plate (air)capacitor.

The given figure shows a network of five capacitors connected to a 100V supply. Calculate the total charge and energy stored in the network.

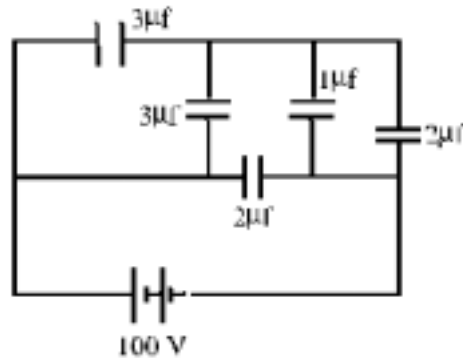

OR

Use Gauss's law to obtain an expression for the electric field due to an infinitely long straight uniformly charged wire.

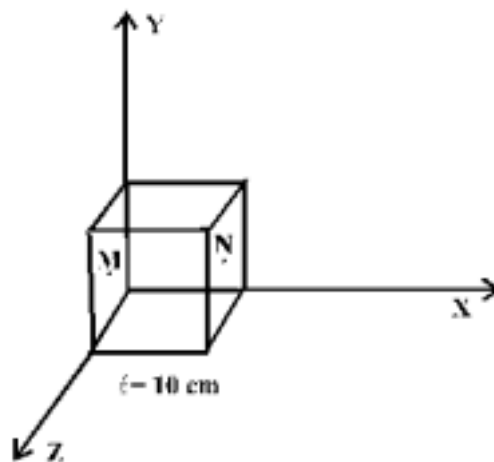

Electric field in the above figure is directed along + X direction and given by $E_x = 5Ax + 2B$, where E is in NC^{-1} and x is in metre, A and B are constants with dimensions Talking $A = 10NC^{-1}m^{-1}$ and $B = 5NC^{-1}$ calculate.

- (i) the electric flux through the cube.
- (ii) net charge enclosed within the cube.

29. (a) Draw the labelled diagram of moving coil galvanometer. Prove that in a radial magnetic field, the deflection of the coil is directly proportional to the current flowing in the coil.
- (b) A galvanometer can be converted into a voltmeter to measure up to
- (i) 'V' volts by connecting a resistance R_1 in series with coil.
- (ii) $\frac{V}{2}$ volts by connecting a resistance R_2 in series with its coil

Find the resistance (R), in terms of R_1 and R_2 required to convert it into a voltmeter that can read up to '2V' volts.

OR

- (a) Draw diagrams to depict the behaviour of magnetic field lines near a 'bar' of:
- (i) copper
- (ii) Aluminium
- (iii) Mercury, cooled to a very low temperature (4.2K)
- (b) The vertical component of the earth's magnetic field at a given place is $\sqrt{3}$ times its horizontal component. If total intensity of earth's magnetic field at the place is 0.4 G find the value of :
- (i) angle of dip
- (ii) the horizontal component of earth's magnetic field.
30. (a) Draw a ray diagram to show the refraction of light through a glass prism. Hence obtain the relation for the angle of deviation in terms of the angle of incidence, angle of emergence and the angle of the prism.
- (b) A right angled isosceles glass prism is made from glass of refractive index 1.5. Show that a ray of light incident normally on
- (i) one of the equal sides of this prism is deviated through 90°
- (ii) the hypotenuse of this prism is deviated through 180°

OR

- (a) With the help of a labelled ray diagram, show the image formation by a compound microscope. Derive an expression for its magnifying power.
- (b) How does the resolving power of a compound microscope get affected on
- (i) decreasing the diameter of its objective?
- (ii) increasing the focal length of its objective?

**MARKING SCHEME
PAPER III
PHYSICS XII**

Q.No.	Value Points	Marks
1.	$E = \text{Energy stored} = \frac{1}{2} CV^2 = \frac{1}{2} \frac{Q^2}{C}$ <p style="text-align: center;">(The graph is showing $E \propto \frac{1}{C}$),</p> <p>Hence Q the charge on capacitors is kept constant</p>	<p>$\frac{1}{2}$</p> <p>$\frac{1}{2}$</p>
2.	$\frac{mv^2}{r} = Bqv, \quad \text{or, } r = \frac{mv}{Bq} = \frac{p}{Bq}$ <p>$\therefore r : r_p = q_p : q_\alpha = \underline{\underline{1 : 2}}$</p>	<p>$\frac{1}{2}$</p> <p>$\frac{1}{2}$</p>
3.	The frequency of the microwaves should match the resonant frequency of the water molecules in the food.	1
4.	'X' is a pure capacitor	$\frac{1}{2}$
	Impedance = $\frac{1}{\omega C}$	$\frac{1}{2}$
5.	$\frac{1}{f} = \left(\frac{\mu_1}{\mu_2} - 1 \right) \left(\frac{1}{r_1} - \frac{1}{r_2} \right)$, the lens would now behave like a diverging (concave) lens.	$\frac{1}{2} + \frac{1}{2}$
6.	$\lambda = \frac{h}{p} = \frac{h}{\sqrt{2mk}}$	$\frac{1}{2}$
	\therefore The proton will have a higher K.E. (mass of proton is slightly less than that of the neutron)	$\frac{1}{2}$
7.	The ionisation energy of silicon gets (considerably) reduced compared to that of carbon. Silicon (a semi-conductor), therefore, becomes a (much) better conductor of electricity than carbon (an insulator)	$\frac{1}{2} + \frac{1}{2}$
8.	$(0 \text{ to } t_1), (t_3 \text{ to } t_4)$	$\frac{1}{2} + \frac{1}{2}$
9.	(i) q_1 is a negative charge and q_2 is a positive charge.	$\frac{1}{2}$
	(ii) $V = \frac{1}{4\pi\epsilon_0} \frac{q}{r} = \frac{q}{4\pi\epsilon_0} \cdot \frac{1}{r}$	$\frac{1}{2}$

∴ Slope of the V v/s $\frac{1}{r}$ graph is $\frac{q}{4\pi \epsilon_0}$ 1/2

Since the slope of the graph for q_1 has a larger magnitude, q_1 has the larger magnitude of the two. 1/2

10. $R_T = R_o [1 + \alpha (T - T_o)]$ 1/2

∴ $\frac{120}{100} = \frac{6}{5} = 1 + \alpha (T - T_o)$ 1/2

∴ $2 \times 10^{-4} (T - 300) = \frac{1}{5}$ 1/2

∴ $T = 1300 \text{ K}$ 1/2

11. $B = \frac{\mu I a^2}{2(a^2 + x^2)^{3/2}} = \frac{\mu_o I}{2a(1 + x^2/a^2)^{3/2}}$ 1/2

∴ $= B_o (1 + x^2/a^2)^{-3/2}$ $\left(\because B_o = \frac{\mu_o I}{2a} \right)$ 1/2

∴ $B \text{ (at } x = a) = B_o (2)^{-3/2} = \frac{B_o \sqrt{2}}{4} = 0.25 \sqrt{2} B_o$ 1/2

and $B \text{ (at } x = 2a) = B_o (5)^{-3/2} = \frac{B_o \sqrt{5}}{25} = 0.04 \sqrt{5} B_o$ 1/2

Thus the given values are in good agreement with the theoretically expected values.

12. $E_{\text{max}} = NBA\omega = NBA \cdot 2\pi \nu$ 1/2

$= 20 \times 0.5 \times 0.09 \times 2\pi \times \frac{150}{\pi} \text{ volt}$ 1/2

$= 270 \text{ V}$ 1/2

$E_{\text{average}} = \text{Zero.}$ 1/2

13. $I = I_1 + I_2$ 1/2

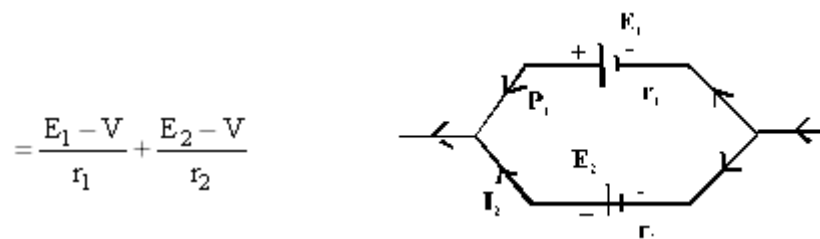

$= \left(\frac{E_1}{r_1} + \frac{E_2}{r_2} \right) - V \left(\frac{1}{r_1} + \frac{1}{r_2} \right)$

∴ $V = \frac{E_1 r_2 + E_2 r_1}{r_1 + r_2} - I \left(\frac{r_1 r_2}{r_1 + r_2} \right)$ 1/2

Comparing with $V = E_{eq} - I r_{eq}$, 1/2

We get $E_{eq} = \frac{E_1 r_2 + E_2 r_1}{r_1 + r_2}$ 1/2

OR

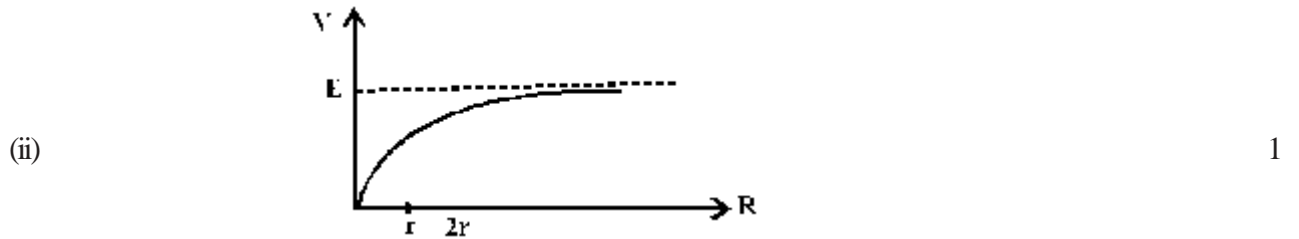
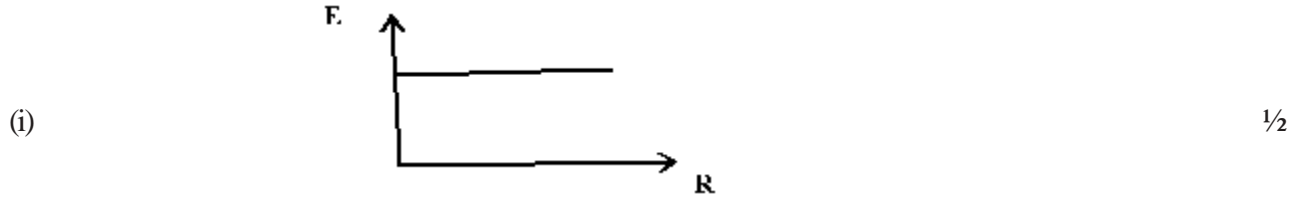

$V = E - i r = E / \left(1 + \frac{r}{R}\right)$ 1/2

14. (i) The glow gradually increases till it becomes maximum 1/2

Reasons : There is a back (induced) emf in the inductor $\left(= -L \frac{di}{dt} \right)$ when the current is growing and this delays the growth of current to its final steady value. 1/2

(ii) The glow will decrease 1/2

Reasons : The impedance of circuit will increase due to the presence of the inductive reactance of the circuit. 1/2

15. (i) UV rays (ii) (UHF) radio waves (iii) Infrared waves 3 x 1/2 = 1 1/2

$\lambda_2 > \lambda_3 > \lambda_1$ 1/2

16. Meaning/Definition of

Depletion region 1

Barrier Potential 1

17. Reasons :

(i) Size of antenna

(ii) Effective power radiated by the antenna

(iii) Mixing up of different signals (Any two reasons with justification)

1+1

18. Angular width $\theta = \frac{\lambda}{a} = \frac{550 \times 10^{-9}}{1 \times 10^{-4}}$ radians

1/2

$$= 5.5 \times 10^{-3} \text{ radians}$$

1/2

Linear width = $D \theta$

$$= 1.1 \times 5.5 \times 10^{-3} \text{ m}$$

$$= 6.05 \text{ mm}$$

1/2

The angular width would not change.

1/2

$$\frac{x}{y} = \frac{60}{40} = \frac{3}{2}$$

19. and $\frac{x}{y+15} = \frac{60-10}{40+10} = 1$

1/2

solving, we get,

$$x = 45 \Omega$$

1/2

$$y = 30 \Omega$$

1/2

For the parallel connection

$$Y' = \frac{30y}{30+y} = \frac{30 \times 30}{30+30} \Omega = 15 \Omega$$

1/2

$$\therefore \frac{x}{y'} = \frac{\ell}{100-\ell}$$

$$\frac{45}{15} = \frac{\ell}{100-\ell} \Rightarrow \ell = 75.0 \text{ cm}$$

OR

The Emf of a cell equals the p.d. between its terminals when it is in an open circuit i.e. not supplying any current. A voltmeter measures p.d. (and not e. m. f.) as it draws a (small) current for its working. The potentiometer draws no (net) current (from the cell) at the balance point. So the cell can be treated as if it were in an open circuit. 1

$$\left. \begin{aligned} E_1 + E_2 &= k (351) \\ \text{and } E_1 - E_2 &= k (70.2) \end{aligned} \right\}$$

1/2

$$\therefore \left. \begin{aligned} \frac{E_1 + E_2}{E_1 - E_2} &= \frac{351}{70.2} = \frac{5}{1} \\ \text{This gives } \frac{E_1}{E_2} &= \frac{3}{2} \end{aligned} \right] \quad \frac{1}{2}$$

20. $X \rightarrow$ a resistor $\frac{1}{2}$

$Y \rightarrow$ A capacitor $\frac{1}{2}$

$$\frac{V}{R} = \sqrt{2} \text{ and } R = X_c$$

$$\therefore I = \frac{V}{2} = \frac{V}{\sqrt{R^2 + X_c^2}} = \frac{V}{R\sqrt{2}} \quad \frac{1}{2}$$

$$\therefore I = \frac{\sqrt{2}}{\sqrt{2}} = 1.0 \text{ A} \quad \frac{1}{2}$$

(iii) Net Impedance

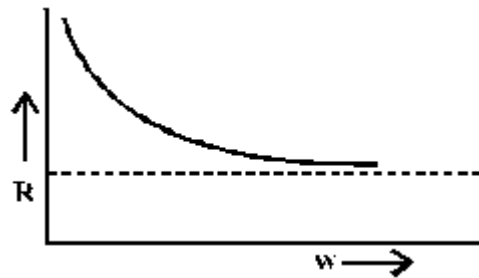

1

21. (i) Because such telescopes $\frac{1}{2}$

(a) have high resolving power $\frac{1}{2}$

(b) produce brighter images $\frac{1}{2}$

(ii) Two identical but independent light sources cannot produce light waves continuously either in the same phase or having a constant phase difference between them. 1

(iii) Brewster angle (i_p) is given by

$$\tan i_p = \mu \quad \frac{1}{2}$$

' μ ' depends upon the wavelength (λ) of the incident light. Hence i_p will be different for different colours of light. $\frac{1}{2}$

22. Work functions

(i) For $M_1 = h\nu_{o1}$ $\frac{1}{2}$

For $M_2 = h\nu_{o2}$ $\frac{1}{2}$

(ii) For M_1

$$h\nu_3 = h\nu_{o1} + eV_1$$

$$\therefore V_1 = \frac{h}{e}\nu_3 - \frac{h\nu_{o1}}{e} \quad \frac{1}{2}$$

Similarly, For M_2 $V_2 = \frac{h}{e}\nu_3 - \frac{h\nu_{o2}}{e} \quad \frac{1}{2}$

$$\therefore V_1 - V_2 = \frac{h}{e}(\nu_{o2} - \nu_{o1}) \quad \frac{1}{2}$$

$$\therefore \text{Slope of either line} = \frac{h}{e} = \frac{V_1 - V_2}{\nu_{o2} - \nu_{o1}} \quad \frac{1}{2}$$

23. Continuous locus of all the particles of a medium which are vibrating in the same phase in called a wavefront. 1
- (a) Difference 1
- (b) Correct explanation with diagram 1

24. The activity of a radioactive element at any instant, equals its rate of decay at that instant. Its SI unit is Becquerel (Bq) (= 1 decay per second) $\frac{1}{2}$

$$\text{Activity } R = -\frac{dN}{dt} = \lambda N = \frac{\log_e 2}{T} N \quad \frac{1}{2}$$

$$\therefore \frac{R_1}{R_2} = \frac{N_1}{T_1} \div \frac{N_2}{T_2} = \frac{N_1 T_2}{N_2 T_1} \quad 1$$

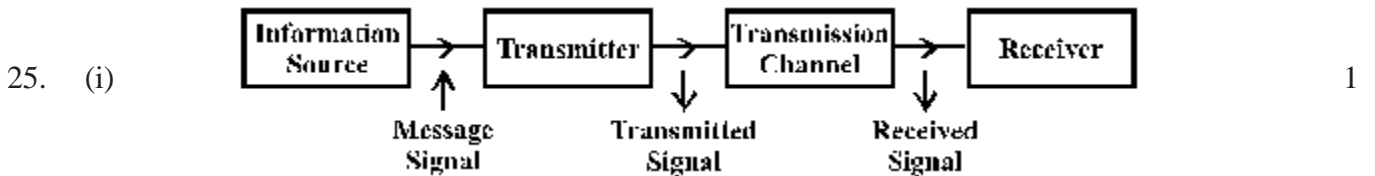

- (ii) Detection is the process of recovering the modulating (or information) signal from the modulated carrier wave. 1

The essential steps followed in the process of detection are

- (i) The AM input wave is passed through a rectifier to obtain its rectified waveform. $\frac{1}{2}$
- (ii) The rectified wave is passed through an 'envelope detector' which retrieves the message signal as the envelope of the rectified wave. $\frac{1}{2}$
26. (i) n - p - n transistor. $\frac{1}{2}$
- (ii) Common emitter $\frac{1}{2}$
- (iii) Considering characteristics for $I_b = 10\mu$ and $I_c = 50\mu A$

$$B = \left(\frac{\Delta I_c}{\Delta I_b} \right) \quad \frac{1}{2}$$

$$= \frac{(8.5 - 2.5) \times 10^{-3}}{(50 - 10) \times 10^{-6}} \quad 1$$

$$= 150 \quad \frac{1}{2}$$

27. The permitted stationary orbits for the electron in a hydrogen atom are those for which the angular momentum of the electron is an integral multiple of $h/2\pi$ 1

$$m v_n r_n = n \frac{h}{2\pi} \quad \frac{1}{2}$$

$$\therefore 2\pi r_n = n \frac{h}{m v} \quad \frac{1}{2}$$

But $\frac{h}{m v_n} = \lambda_n$ the associated de Broglie wavelength for electron in its n^{th} orbit 1/2

Hence $2\pi r_n = n \lambda_n$

or circumference of n^{th} permitted orbit
 = $n \times$ de Broglie wavelength
 associated with the electron in the n^{th} orbit. 1/2

28. Derivation of expression for capacitance $C = \frac{A \epsilon_0}{d}$ 2

Net capacitance = $4\mu\text{F}$ 1

Energy stored (W) = $\frac{1}{2} C V^2$ 1/2

= 0.02 J 1/2

Charge $q = CV$ 1/2

= $4 \times 10^{-4} \text{ coulomb}$ 1/2

OR

Derivation of Diagram 1/2

$$E = \frac{\lambda}{2\pi \epsilon_0 r} \quad 1 \frac{1}{2}$$

$E = 5Ax + 2B = 50x + 10$ 1/2

Electric flux through the face with point M on it

$$\phi_1 \equiv \vec{E} \cdot d\vec{s} = E ds \cos 180^\circ \quad \frac{1}{2}$$

$$\phi_1 = -E_1 ds = -(0+10) \times 0.01$$

$$= 0.1 \text{ NC}^{-1}\text{m}^2$$

similarly, flux through the face having point 'N' on it.

$$\phi_2 = E_2 ds \cos 0^\circ$$

$$= (50 \times 0.1 + 10) \times 0.01$$

$$= 0.15 \text{ NC}^{-1}\text{m}^2$$

1/2

(Flux through all other faces will be Zero)

∴ Total flux through the cube

$$= \phi_1 + \phi_2 = -0.1 + 0.15$$

$$= 0.05 \text{ NC}^{-1}\text{m}^2$$

1/2 + 1/2

(ii)
$$\phi = \frac{q}{\epsilon_0}$$

$$\therefore q = \epsilon_0 \phi$$

1/2

$$= 44.25 \times 10^{-14} \text{ C}$$

1/2

29. (a) Labelled diagram of moving coil galvanometer

1

Deflecting torque on the coil = $NI BA \sin \theta$

In radial magnetic field $\theta = 90^\circ$

∴ Deflecting torque = $NIA B$

Counter torque provided by the spring = $K \phi$

1/2

∴ In equilibrium

$$K \phi = NIAB$$

1/2

$$\therefore \phi = \left(\frac{NBA}{K} \right) I$$

The quantity in bracket is constant

$$\therefore \phi \propto I$$

1/2

$$R_1 = \frac{V}{I_g} - G \quad \therefore \frac{V}{I_g} = R_1 + G$$

1/2

and
$$R_2 = \frac{V}{2I_g} - G \quad \therefore \frac{V}{I_g} = 2R_2 + 2G$$

1/2

On comparison $G = R_1 - 2R_2$

1/2

$$\therefore R_3 = \frac{2V}{I_g} - G$$

1/2

$$= 2(R_1 + G) - G = 2R_1 + G$$

$$= 2R_1 + R_1 - 2R_2 = 3R_1 - 2R_2$$

1/2

OR

We know that (i) copper is diamagnetic (ii) Aluminium is paramagnetic and (iii) mercury (cooled to 4.2 k) is perfect diamagnetic. Hence the behaviour of field lines is as shown here

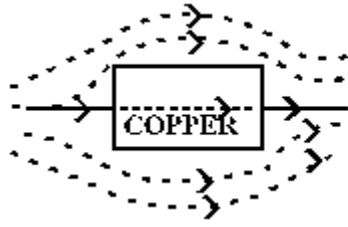

(i)

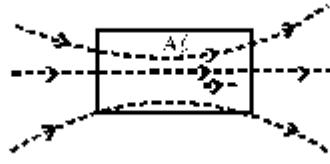

(ii)

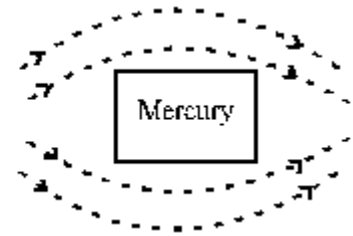

(iii)

$$(b) (i) \tan \theta = \frac{V}{H} = \frac{\sqrt{3}H}{H} = \sqrt{3}$$

1/2

$$\therefore \theta = \tan^{-1}(\sqrt{3}) \text{ or } 60^\circ$$

1/2

$$(ii) \text{Horizontal Component} = B_E \cos \theta = B_E \cos 60^\circ$$

1/2

$$= 0.4 \times \sqrt{3/2}$$

1/2

$$= 0.346 \text{ G}$$

30. (a) Ray diagram

1

Proving $r_1 + r_2 = A$

1/2

getting the relation

$$\angle \delta = \angle i + \angle e - \angle A$$

(b) Calculating the critical angle for glass

1/2

Drawing the ray diagram for case (i)

1

Drawing the ray diagram for case (ii)

1

OR

(a) Labelled ray diagram

1

$$\text{Derivation} \quad m = \frac{L}{f_0} \left(1 + \frac{d}{f_e} \right)$$

2

(b) Resolving power of microscope

$$R.P. = \frac{2\mu \sin \beta}{1.22 \lambda}$$

(i) Decreasing diameter of objective will decrease β Hence R.P. will decrease

1

(ii) No effect

1